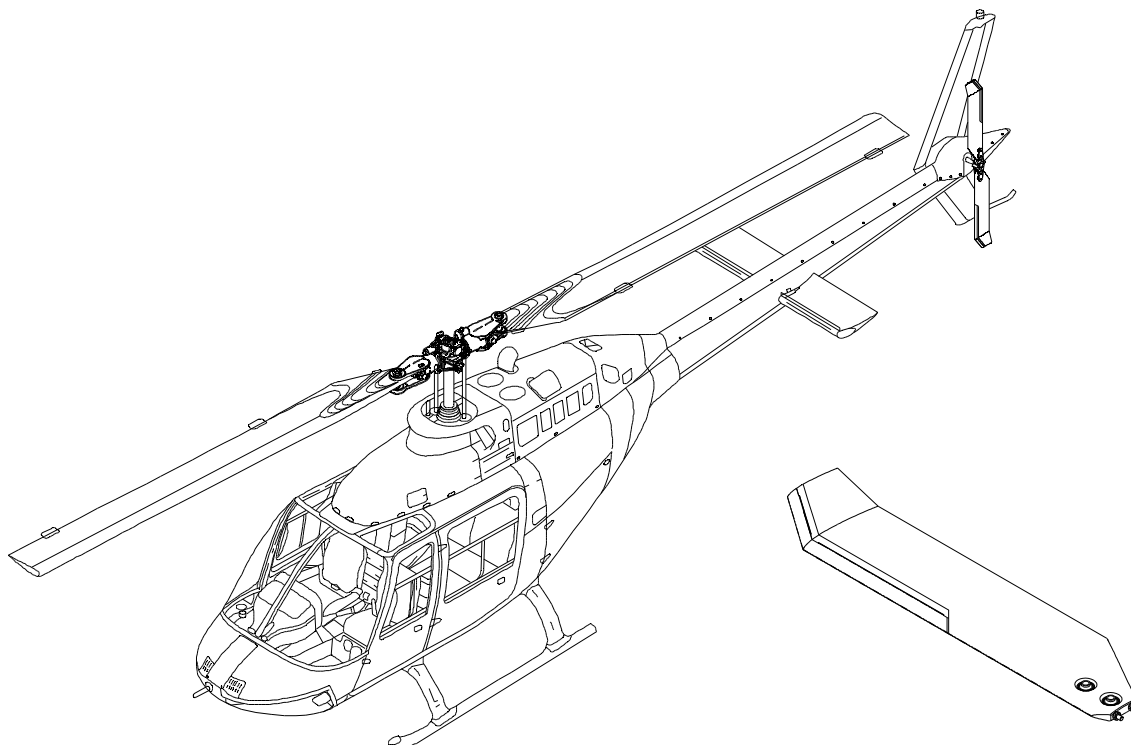


**INSTALLATION & MAINTENANCE MANUAL  
for Composite Tail Rotor Blade  
Part Number AMT-206-1  
Supplemental Type Certificate SVR 520**



**Tail Rotor Blade AMT-206-1**

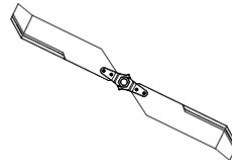
Document No. **CTRB-IMM**

Date: **30th May 2015**

Revision: **2**

**A.M.T. HELICOPTERS PTY. LTD. PROPRIETARY INFORMATION**

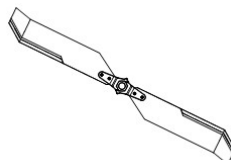
The information contained in this document is AMT Helicopters Pty Ltd (T/as Airwork Helicopters) Proprietary Information and is disclosed in confidence. It is the property of Airwork Helicopters and shall not be used, disclosed to others or reproduced without the express written consent of Airwork Helicopters. If consent is given for reproduction in whole or in part, this notice shall appear in any such reproduction in whole or in part.



## TABLE OF CONTENTS

### Contents

A.M.T. Helicopters Pty. Ltd. Proprietary Information.....	1
1.0 Introduction.....	4
1.1 Scope.....	4
1.2 Acronyms.....	4
1.3 Terminology and Definitions.....	4
1.4 Revision History.....	5
1.5 Installation Eligibility.....	5
1.6 General.....	6
1.7 Airworthiness Limitation.....	7
1.8 Specifications and Limitations.....	7
1.9 Design Description.....	8
1.9.1 The Nickel Abrasion Strip.....	8
1.9.2 Spherical Bearings.....	10
2.0 Installation Instructions.....	12
2.1 Fitting Blades to Hub Assembly.....	12
2.2 Balancing.....	12
2.3 Rigging.....	13
2.4 Final Installation Check before Returning the Aircraft to Service.....	15
3.0 Maintenance and Inspections.....	16
3.1 Documentation and History.....	16
3.2 Maintenance Schedule Summary.....	16
3.3 Routine Maintenance.....	17
3.4 Pre-flight Inspection.....	17
3.5 Periodic Scheduled Maintenance Inspection 100 Hour Inspection or Annually.....	19
3.5.1 General.....	19
3.5.2 Maintenance Inspection Requirements.....	21
3.6 Special Inspections.....	25
3.6.1 Sudden Stoppage or Acceleration.....	25
3.6.2 Lighting Strike.....	25
3.6.3 Overspeed or Overtorque.....	25
3.6.4 Painting.....	26
4.0 Trouble Shooting.....	27
4.1.1 Balancing Difficulty.....	27
4.1.2 In Flight Vibrations.....	27
5.0 Shipping Return to Factory.....	28
5.1 Required Paper Work.....	28
5.2 Suggested Packaging.....	28
5.3 For questions or service contact:.....	28

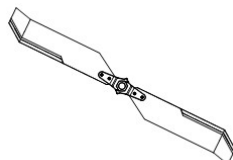


## Figures

Figure 1 – Blade Overview.....	6
Figure 2 – Nickel Abrasion Strip.....	8
Figure 3 – Nickel Abrasion Strip and Urethane Adhesive, exploded view.....	9
Figure 4 – Spherical Bearings (Blade Installation).....	10
Figure 5 – Spherical Bearings (Blade Section View).....	11
Figure 6 – Typical Spherical Bearing.....	11
Figure 7: Tail Rotor Blade AMT-206-1 Rigging.....	14
Figure 8: Preflight Spherical Bearing wear/movement Check.....	18
Figure 9: Tail Rotor Blade AMT-206-1 Zone Definition.....	20
Figure 10 – Premissible Spherical Bearing movement.....	22

## Tables

Table 1.1: Revisions.....	5
Table 1.2: Installation Eligibility.....	5
Table 1.3: Airworthiness Limits.....	7
Table 3.1: Periodic Maintenance Inspections.....	16
Table 3.2: Type of Damage and limits.....	24



## **1.0 INTRODUCTION**

### **1.1 SCOPE**

This Installation and Maintenance Manual provides information and procedures for the fitment, inspection and maintenance of the the Tail Rotor Blade AMT-206-1.

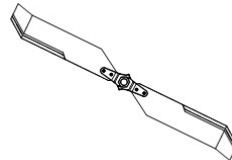
### **1.2 ACRONYMS**

BAFM	Basic Airplane Flight Manual
EIS	Engineering Instruction Sheet
FAA	Federal Aviation Administration (USA)
IAW	In accordance with
NDT	Non-destructive test
OEM	Original Equipment Manufacturer
P/N	Part Number
STC	Supplementary Type Certificate
TCDS	Type Certificate Data Sheet
TRB	Tail Rotor Blade

### **1.3 TERMINOLOGY AND DEFINITIONS**

The following is a list of commonly referred to Definitions and Terms used in this document:

Factory	A.M.T. Helicopters Pty Ltd T/as Airwork Helicopters PO Box 857, 5/19 Lear Jet Drive, Caboolture, QLD, 4510 Australia ABN: 78 006 385 324 Phone: +61 7 5495 8000 Fax: +61 7 5495 8008 Email: <a href="mailto:info@airwork.com.au">info@airwork.com.au</a> Web: <a href="http://www.airwork.com.au">www.airwork.com.au</a>
Bushing or Bearing or Spherical Bearing	The term used to represent the bearing located at the blade attachment points (qty 2). The bearing is of a spherical type which permits the angular movement of the bolt axis and also rotation of the spherical ball within the race.
Retainer Ring	The aluminium ring that is integral to the composite layup of the blade which permits the attachment of the spherical bearing (swaged in place)



#### 1.4 REVISION HISTORY

Issue No.	Description	Date	Approval
IR	Initial Revision	19th November 2014	-
1	Document Revised	28 <sup>th</sup> May 2015	-
2	Installation Eligibility revised	30 <sup>th</sup> May 2015	-

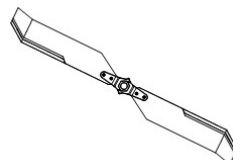
*Table 1: Revisions*



**1.5 INSTALLATION ELIGIBILITY**

Part Name	Part Number	Approved Modification Part Number/Replacement for Part Number	Approval Basis and Approved Design Data	Make Eligibility	Model Eligibility
Composite Tail Rotor Blade	AMT-206-1	206-016-201-001	Test and Computation  STC-SVR520 Original Issue (or later approved Revision)	Bell Helicopter Textron  AMT  OSBORNE AVIATION	206A 206B 206L  AMT-OH-58A  OH-58A
		206-016-201-107			
		206-016-201-113			
		206-016-201-127			
		206-016-201-131			
		206-016-201-135			
		206-016-201-103			
		206-016-201-125			
		206-016-201-133			
		206-016-201-137			
206-010-750-109					

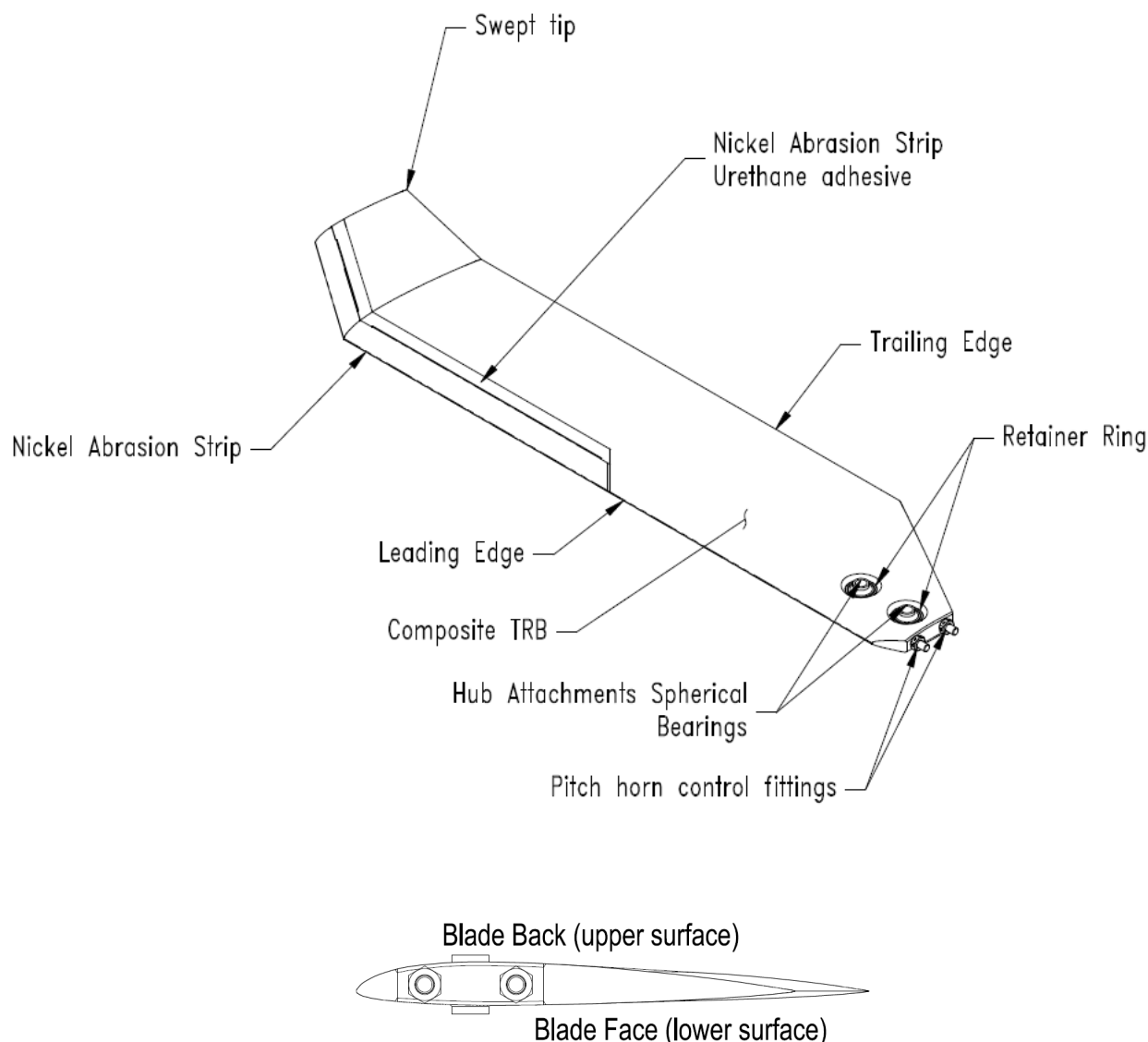
*Table 2: Installation Eligibility*



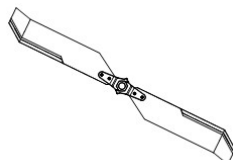
## 1.6 GENERAL

The AMT-206-1 tail rotor blade is manufactured in Australia in association with Hertelendy Research USA (HRA) and eligible to fit to aircraft noted in Section 1.5 , Installation Eligibility.

The AMT-206-1 composite tail rotor blade is direct replacement for the Bell 206 TRB. The AMT-206-1 TRB has a non-symmetrical airfoil section and incorporates a swept tip. The blade is primarily fabricated from uni-directional Graphite and Aramid continuous fibres suspended in an epoxy matrix and is fitted with a nickel abrasion strip on the leading edge. The abrasion strip is bonded on using a urethane adhesive.



**Figure 1 – Blade Overview**



## 1.7 AIRWORTHINESS LIMITATION

Part Number	Description	Airworthiness Limit
AMT-206-1	Composite Tail Rotor Blade	5000 hours TIS

Table 3: Airworthiness Limits

## 1.8 SPECIFICATIONS AND LIMITATIONS

**NO DAMAGE TO THE TRB IS PERMITTED.**

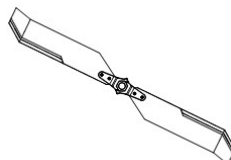
**NO FIELD REPAIRS ARE PERMITTED**

The abrasion strip and Spherical Bearings are replaceable by AMT Helicopters (Referred to herein as 'the factory') using approved tooling and procedures. These items may require replacement prior to the expiration of the 5000 flight hours limit depending on the environmental conditions in which the blade is being operated.

**WARNING**

**EXPOSURE OF THE AMT-206-1 BLADES TO FUELS, OILS, SOLVENTS,  
STEAM OR HOT WATER CLEANERS NOT PERMITTED**





## 1.9 DESIGN DESCRIPTION

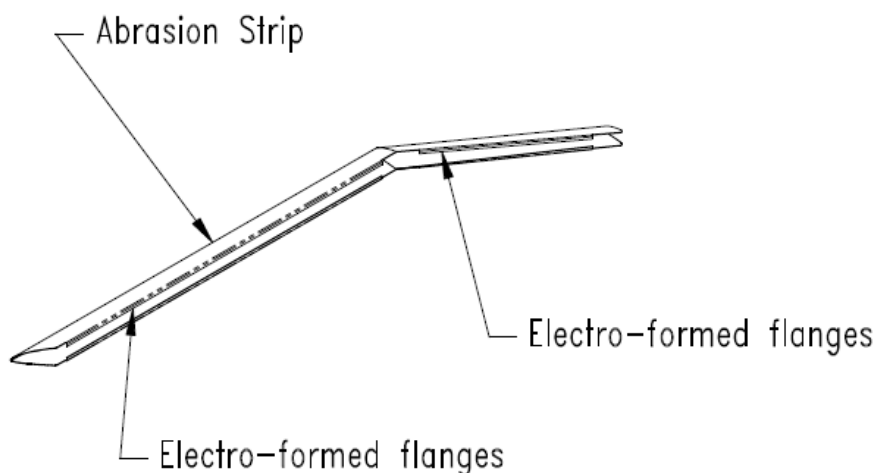
The AMT-206-1 tail rotor blade is designed around a mix of aramid, carbon and glass fibres that are bound in an epoxy matrix. The design incorporates a stainless steel mesh embedded in the surface coat to provide lightning protection

The use of a different airfoil and increased chord length reduces the tail rotor diameter, increases the ground clearance and reduces the tail rotor noise while maintaining full control authority and provides improved tail rotor performance/authority when compared to the OEM TRB's.

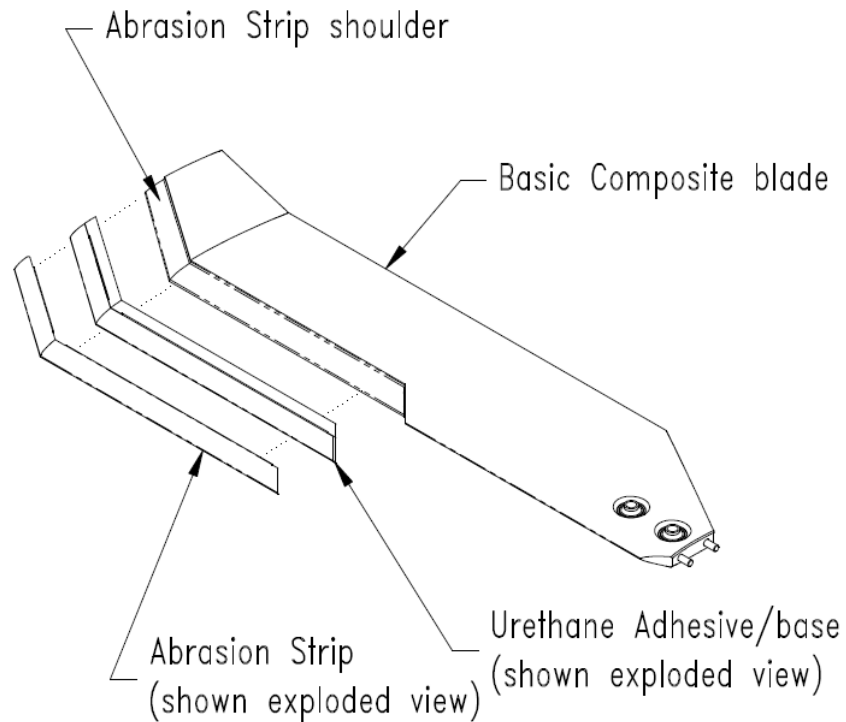
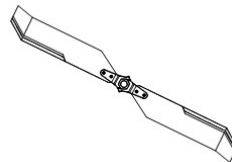
### 1.9.1 The Nickel Abrasion Strip

AMT-206-1 blades are equipped with a nickel electroformed abrasion strip. The abrasion strip incorporates a unique design by A.M.T. Helicopters Pty Ltd in where there is a mechanical tab along a large portion of the abrasion strip, which mechanically fastens the abrasion strip to the urethane adhesive, consequently the nickel strip is held both by adhesion and mechanically.

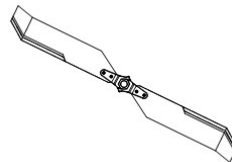
The leading edge abrasion strip may only be replaced by qualified A.M.T. Helicopters Pty Ltd trained persons using A.M.T. Helicopters Pty Ltd tooling, procedures and A.M.T. Helicopters Pty Ltd supplied materials.



*Figure 2 – Nickel Abrasion Strip*

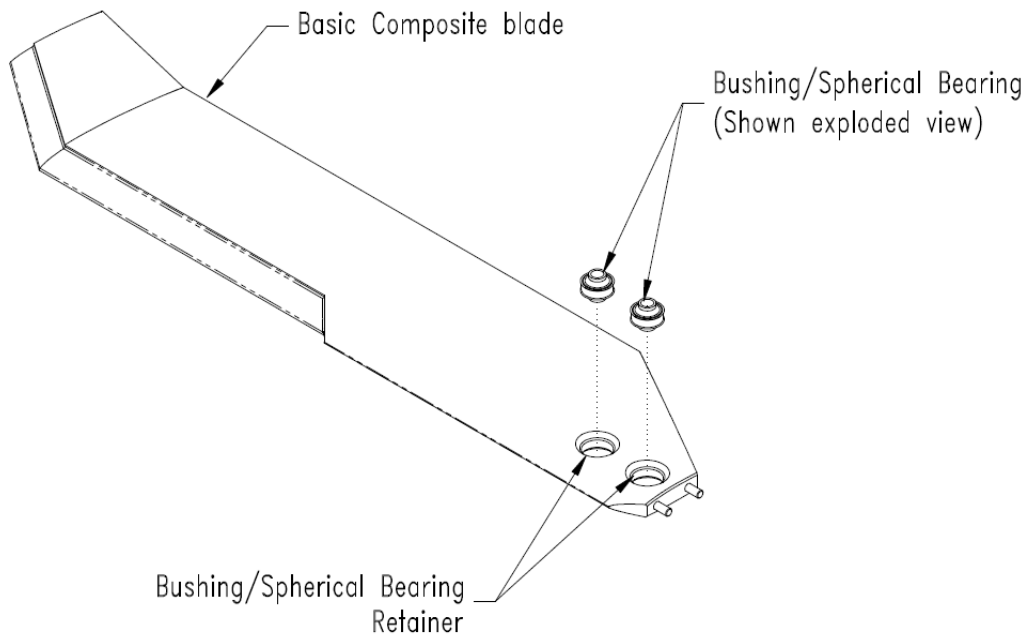


**Figure 3 – Nickel Abrasion Strip and Urethane Adhesive, exploded view**

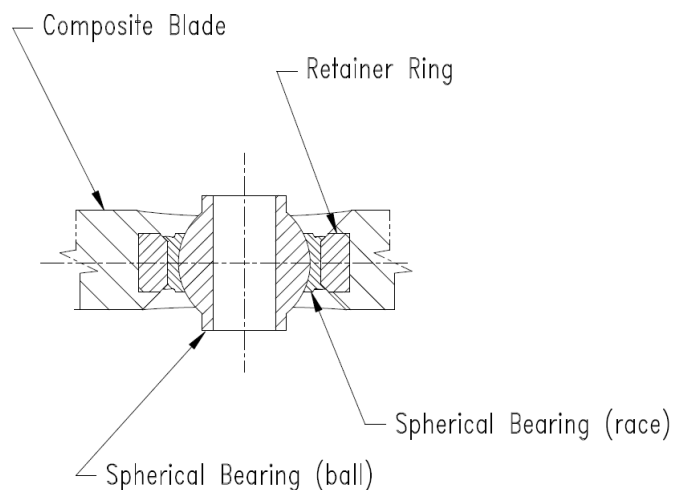


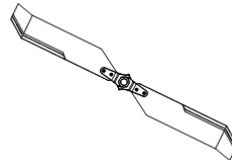
### 1.9.2 Spherical Bearings

The blade is fitted with two HAC-SSW Spherical Bearings which permit the blade pitch angle to be adjusted. The two Spherical Bearings are NOT field replaceable and may only be replaced by the factory (A.M.T. Helicopters Pty Ltd) using procedures and tooling approved by A.M.T. Helicopters Pty Ltd.

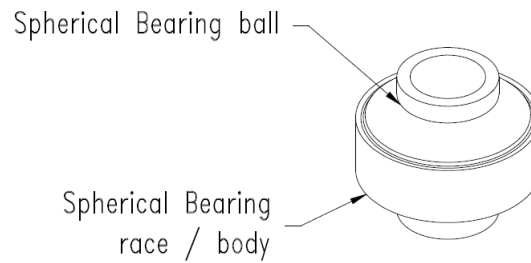


**Figure 4 – Spherical Bearings (Blade Installation)**

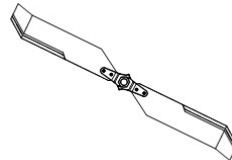




**Figure 5 – Spherical Bearings (Blade Section View)**



**Figure 6 – Typical Spherical Bearing**



## 2.0 INSTALLATION INSTRUCTIONS

### 2.1 Fitting Blades to Hub Assembly

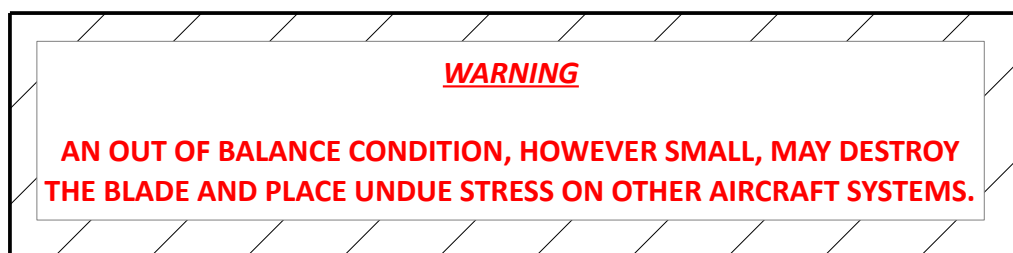
There are no unique installation requirements for the AMT-206-1 composite blade excluding the requirement for a positive adjustment in the neutral pitch angle (+1.5 degrees). The blades should be fitted to the hub assembly IAW Bell 206 Component Repair and Overhaul Manual Latest Revision.

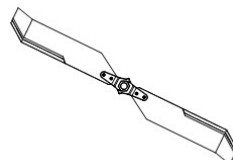
During pitch horn installation care must be taken not to over-torque the pitch horn ring retention nuts. A torque wrench of no greater capacity than 250 lbs/inch (28.5Nm) should be used and the nuts should be torqued to only 36 lb/inch (4 Nm). Larger torque wrenches are not accurate enough to use at this low setting and may cause “over-torquing” the nuts, shearing the “anti-rotational” pins and pulling through the studs. After torquing, ensure the nuts are securely lock wired using .032” safety wire.

### 2.2 Balancing

The pitch horn ring, blade and hub assembly should be statically balanced when any blades are fitted prior to fitting the hub and blade assembly to the helicopter. Static balancing should be carried out in accordance with Bell 206 Component Repair and Overhaul Manual latest Revision or the Bell 206 Component Repair and Overhaul manual Latest Revision.

After static balancing and installation of the hub and blade assembly on the helicopter, final balancing should be accomplished using a “Vibrex” or similar dynamic balancing system.





### 2.3 Rigging

- a. Check rigging of aircraft is IAW AMM.
- b. Set the tail rotor blades to the horizontal position using inclinometer, and set tail rotor hub to 0.0° in the lateral direction and lock with centering tool T101741-101 or foam work aid supplied against bump stop rubber and hub.
- c. Set pedals to the neutral (centre) position
- d. With the rigging set as per steps a, b and c above, affix pitch angle tool (AMT-101) supplied using zip ties or equivalent.
- e. Using inclinometer against foam tool AMT-101, adjust control tube to bell crank rod end to set pitch angle to +1.5° (positive one point five degrees). The trailing edge will be away from the aircraft. Refer to Figure 7: Tail Rotor Blade AMT-206-1 Rigging.
- f. Re-torque and cotter pin rod end nut.
- g. Check full left and right pedal travel to ensure clearance from hub.

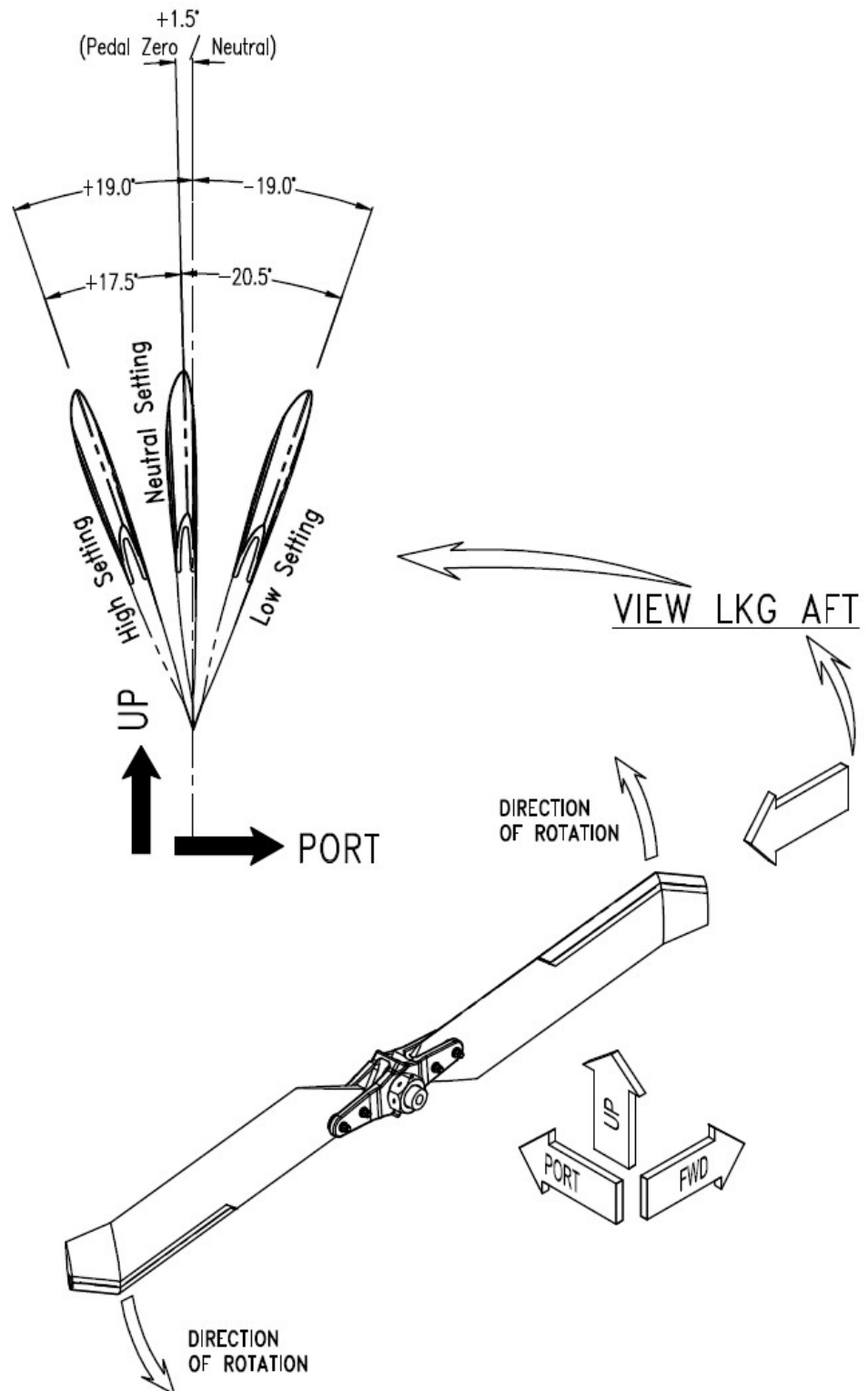
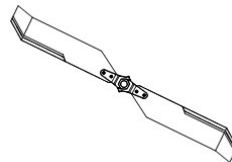
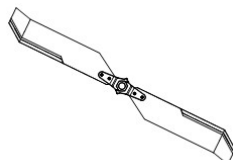


Figure 7: Tail Rotor Blade AMT-206-1 Rigging

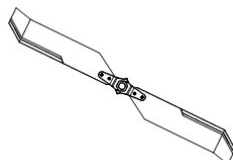


---

## **2.4 Final Installation Check before Returning the Aircraft to Service**

- a. Recheck pitch horn attach nuts and safety wiring.
- b. Recheck blade bolts for tightness.
- c. Check tail rotor pedals for freedom of movement.
- d. Carry out dynamic balance procedure.
- e. Ensure Blade Log CTRB-F19 (History Card) has been entered with aircraft Total Time in Service (TTIS) and that all appropriate entries including dates for removal and fitting of blades is complete and signed for.
- f. Ensure log book entry is complete for fitting of blades detailing Part Number, Serial Number, STC and APMA numbers.





### 3.0 MAINTENANCE AND INSPECTIONS

#### 3.1 DOCUMENTATION AND HISTORY

The AMT-206-1 composite blade is a life limited, flight critical component and as such it is necessary to track its service history. This is accomplished by the use of a Blade Log CTRB-F19 (History Card) supplied with the blade by A.M.T. Helicopters Pty Ltd at the initial time of purchase.

Without the A.M.T. Helicopters factory supplied Blade Log CTRB-F19 (History Card) the blade is **NOT AIRWORTHY**. After surrendering a completed, legible Blade Log CTRB-F19 (History Card) A.M.T Helicopters may issue a replacement Blade Log CTRB-F19 (History Card) and will keep the replaced Blade Log CTRB-F19 (History Card) on file at the factory with the blade's fabrication records.

Blades that have the factory fitted, approved metal data plate removed or missing or showing signs of tapering are **NOT AIRWORTHY** and should be immediately withdrawn from service.

The AMT-206-1 blades are approved under CASA STC SVR 520 for installation on Bell 206 A/B and AMT OH-58A helicopters and require only a log book entry at installation.

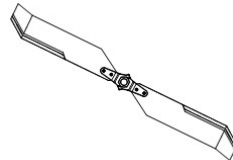
Upon removal, installation on another aircraft or shipping, the Blade Log CTRB-F19 (History Card) must be correctly filled out and must accompany the blade (if not installed) or the Aircraft Log Book at all times.

Blade Logs CTRB-F19 (History Card) must be signed off by an appropriately qualified mechanic, Licensed Aircraft Maintenance Engineer or Authorised Repair Station Inspector.

#### 3.2 MAINTENANCE SCHEDULE SUMMARY

Item	Description	Airworthiness Criteria	Reference Section
1	Routine Maintenance	As required Nil Damage / Defects	3.3
2	Preflight Inspection	Nil Damage / Defects	3.4
3	100 Hourly and Annually	Nil Damage / Defects	3.5
4	Special Inspection	Nil Damage / Defects Factory Repairable only	3.6

Table 4: Periodic Maintenance Inspections



### **3.3 ROUTINE MAINTENANCE**

Wash blades with soap and water (warm or cold). Blades may be further cleaned with a denatured alcohol soaked cloth to remove grease and other sticky substances.

Do not use solvents or fuels. Do not use denatured alcohol in any quantity or time on the urethane adhesive securing the nickel abrasion strip.

The Spherical Bearings are self lubricating using a PTFE type material. Any introduced lubrication swells the liner and causes premature Spherical Bearing wear.

### **3.4 PRE-FLIGHT INSPECTION**

- a. Visually inspect the nickel abrasion strip for any signs of damage, including, but not limited to, dents, gouges scratches broken urethane adhesive or cracks. None permitted.
- b. Check for Spherical Bearing wear by immobilising the hub with one hand and moving the blade tip perpendicular to the blade surface (side to side). A maximum of 3/16" travel (at the tip) is permissible, this corresponds to a maximum spherical bearing ball movement of 0.005" and is a suitable means for a on aircraft determination of the wear / movement of the spherical bearings. Where doubt exists maintenance personnel are to be notified. Refer to 5Figure 8: Preflight Spherical Bearing wear/movement Check.
- c. Check blade for cracks, paying particularly attention to the area between the inboard/outboard Spherical Bearings /retaining rings and the leading edge. Cracking in the blade may be indicated (but not limited to) by cracks in the paint. None is permitted.
- d. Check pitch horn ring mounting by trying to move it relative to the blade. No movement is permitted.
- e. Where any damage is identified during the pre flight or subsequently, the rotorcraft is not to be operated and maintenance personnel are to be notified

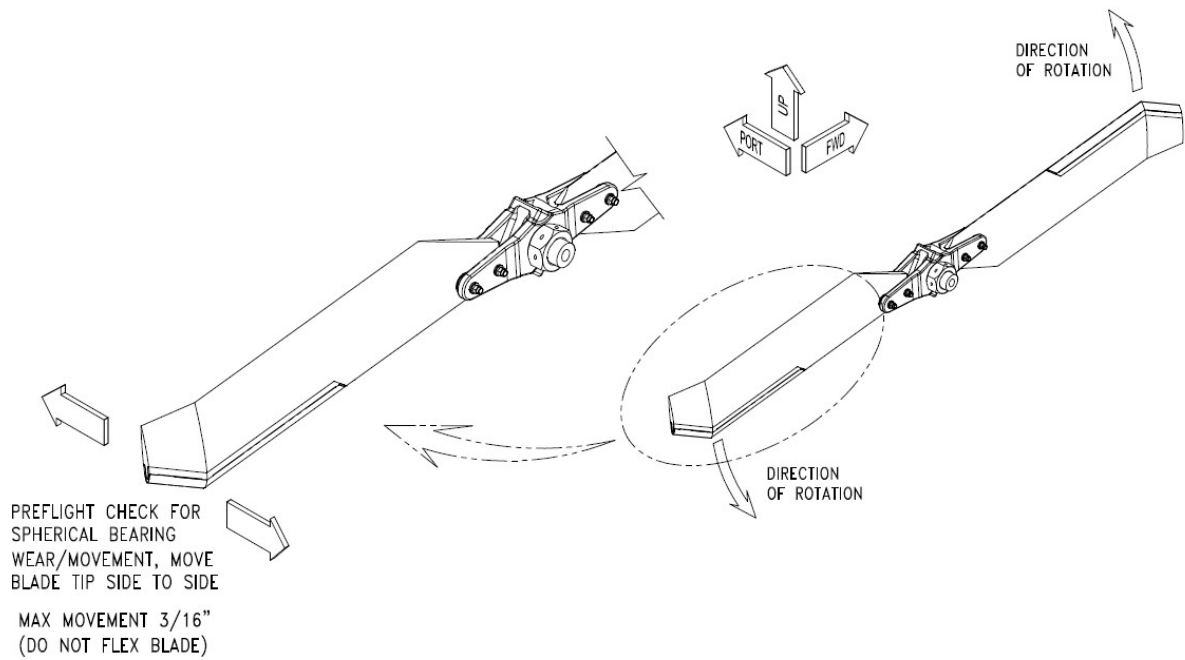
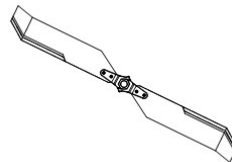
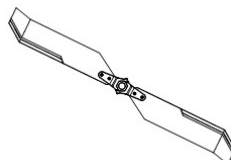


Figure 8: Preflight Spherical Bearing wear/movement Check



### **3.5 PERIODIC SCHEDULED MAINTENANCE INSPECTION 100 HOUR INSPECTION OR ANNUALLY**

#### **3.5.1 General**

For scheduled maintenance inspection, the blades should be removed from the hub, but pitch horns do not have to be removed.

Clean blades thoroughly with soap and water. Remove grease and oil residue with denatured alcohol soaked rag. Observe precautions listed under Routine Maintenance.

The inspection and results of the inspection shall be entered in the aircraft log book.

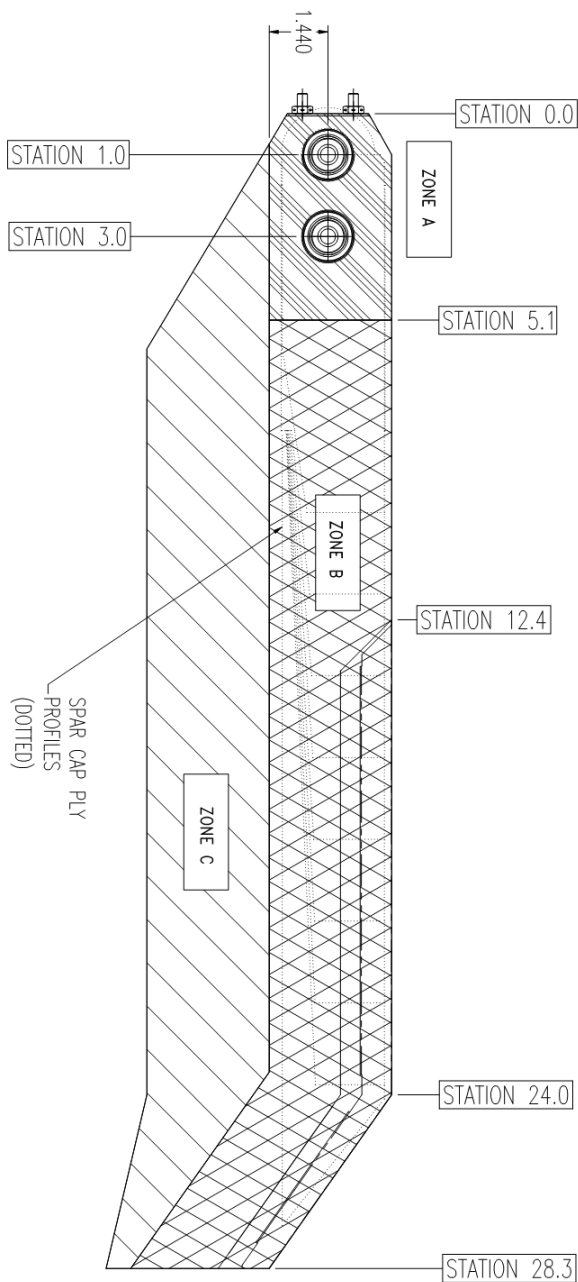
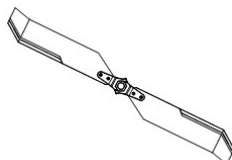
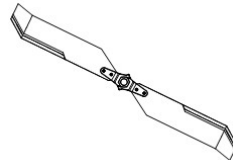


Figure 9: Tail Rotor Blade AMT-206-1 Zone Definition



### 3.5.2 Maintenance Inspection Requirements

**Note:**

Cracking in the paint may be an indication of cracking in the substrate structure or simply a sign of the top coat paint cracking. Care must be taken to identify the type crack present, if any. At the very minimum a crack in the paint must be verified to be such using the tap-test method, refer to *FAA Advisory Circular AC43.13-1B, Change 1, September 08, 1998 (or latest revision) Section 8. Tap Testing*.

Where doubt exists, the factory is to be contacted for assessment.

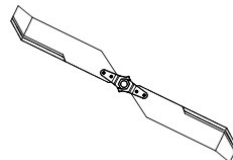
Unless noted otherwise, the blade assembly must be uniform in quality, appearance and condition and free of foreign material and internal or external imperfections.

**a. Thoroughly inspect the blade for damage.**

- i ) Inspect around each Spherical Bearings / retainer ring cavity (Zone A) for cracks on both surfaces. No cracks are permitted. If there is a crack the blade is **NOT AIRWORTHY**.
- ii ) Inspect the blade at STA 3.0 (inline with the outer attachment Spherical Bearing) (Zone A) for cracking. No cracks are permitted
- iii ) Inspect the rest of the blade for cracks (Zone B and C) . No cracks are permitted.
- iv ) Where a crack is found and suspected to be in the paint work only, perform a inspection using the tap-test method, refer to *FAA Advisory Circular AC43.13-1B, Change 1, September 08, 1998 (or latest revision) Section 8. Tap Testing* to verify cracking is only in the paint work and not the substrate structure. Where doubt exists, the factory is to be contacted for assessment.

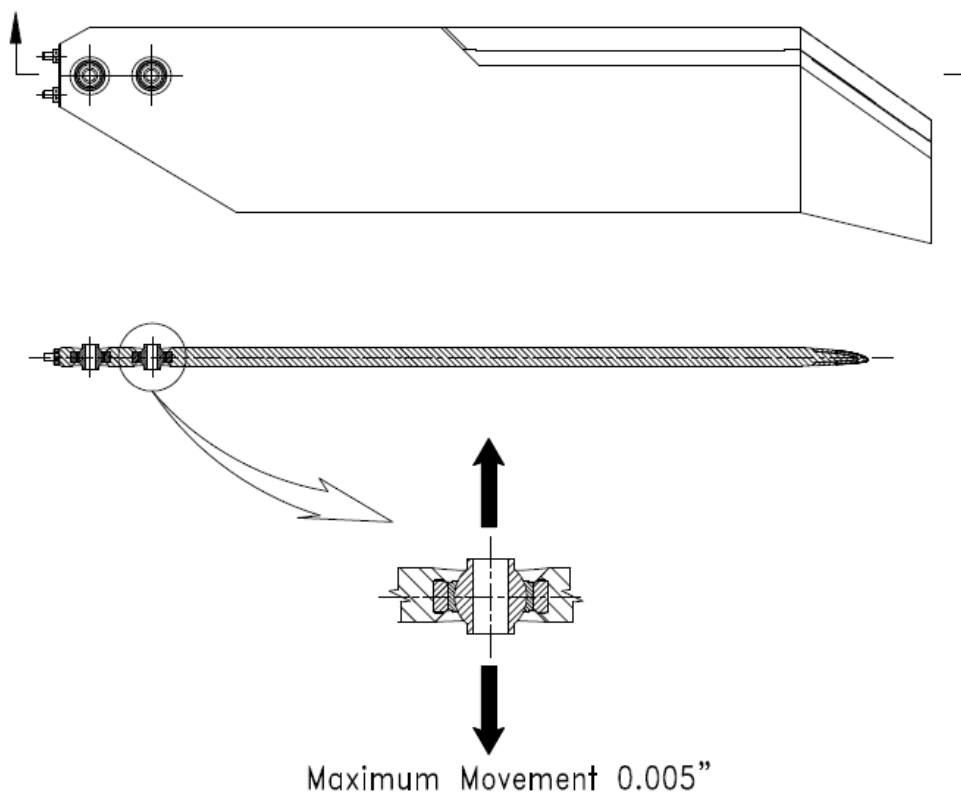
**b. Inspect the pitch horn ring attachment. It should be firm with no movement present. No movement is permitted.**

- i ) If there is movement, remove the safety wire from the attachment nuts and re-torque the nuts to 36 lb/inch (4 Nm).
- ii ) If either of the nuts cannot be re-torqued the blade is **NOT AIRWORTHY**.
- iii ) Where successful retorquing is achieved ensure safety wire is reapplied correctly.

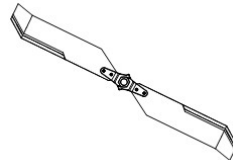


c. **Inspect Spherical Bearings for wear and retention:**

- i ) Visually inspect torque-lock paint (applied between the spherical bearing race and retaining ring) to ensure the Spherical Bearings (Body) has not moved from the retainer ring. No movement is permitted. If there is indication of Spherical Bearing movement with respect to the retainer ring the blade is **NOT AIRWORTHY**. The blade must be repaired by the factory if deemed possible.
- ii ) Place the blade in a soft jaw vice secured by the Spherical Bearing end flanges (the ball). Check for Spherical Bearing wear by trying to move the blade from side to side (attempting to translate the Spherical Bearing ball out of the race and blade). No movement over 0.005" is permitted. If there is an indication of movement greater than 0.005" the blade is **NOT AIRWORTHY** and must be repaired by the factory if deemed possible.

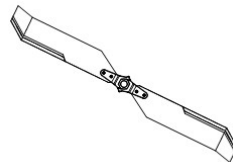


**Figure 10 – Permissible Spherical Bearing movement**



- d. **Inspect abrasion strip and abrasion strip urethane adhesive:**
- e. Inspect for security and condition of the mounting of the abrasion strip (Zone B).
  - f. Inspect for damage. None permitted.
  - g. No separation of the abrasion strip (Zone B) from the urethane impact cushion is permitted. Inspect the visible urethane adhesive for conditions, nicks, cuts or other damage is not permitted. Blades that show abrasion strip separation or nicks, in the urethane adhesive are **NOT AIRWORTHY** but may be repairable by the factory
  - h. The inspection and the results of the inspection should be entered in the aircraft's log book and where the TRB is deemed NOT AIRWORTHY the blade appropriately tagged, quarantined and rectification action (return to factory) provided.



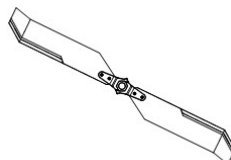


Type of Damage	Acceptability and extent of Damage	Test Method	Repair
Damage, defect or imperfection that penetrates through the lightning mesh.	None permitted	Visual. Damage can be identified by visible broken or misaligned lightning mesh filaments	Blade Unserviceable
Delamination and Internal Voids	None permitted	Visual and Tap test per FAA Advisory Circular AC43.13-1B, Change 1, September 08, 1998 (or latest revision) <i>Section 8. Tap Testing</i>	Blade unserviceable
Surface Scratches	None permitted	Visual	Repair may be possible by the factory
Partial Fractures	None permitted	Visual and Tap test per FAA Advisory Circular AC43.13-1B, Change 1, September 08, 1998 (or latest revision) <i>Section 8. Tap Testing</i>	Blade Unserviceable
Pitch Horn Studs movement	None permitted	Visual and using a torque wrench 36 lb/inch (4 Nm)	Blade Unserviceable
Spherical Bearing movement	0.005" Maximum	Place blade in suitable retaining device (soft jaw vice) and attempt to slide the Spherical Bearings out of the blade.	Repair may be possible by the factory
Abrasion Strip Damage	None permitted	Visual and Tap test per FAA Advisory Circular AC43.13-1B, Change 1, September 08, 1998 (or latest revision) <i>Section 8. Tap Testing</i>	Repair may be possible by the factory
Urethane Adhesive Damage	None permitted	Visual	Repair may be possible by the factory

Table 5: Type of Damage and limits

**Note:**

Any repair must be carried out by a qualified A.M.T. Helicopters Pty Ltd personnel and who uses A.M.T. Helicopters Pty Ltd parts and procedures. Blades must be returned to the factory for assessment and/or repair.



### 3.6 SPECIAL INSPECTIONS

#### 3.6.1 Sudden Stoppage or Acceleration

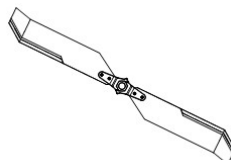
- a. AMT-206-1 TRB 's are **NOT AIRWORTHY** . Return to Factory for assessment.

#### 3.6.2 Lighting Strike

- a. AMT-206-1 TRB 's are **NOT AIRWORTHY** . Return to Factory for assessment.

#### 3.6.3 Overspeed or Overtorque

- a. AMT-206-1 TRB 's are **NOT AIRWORTHY** . Return to Factory for assessment.

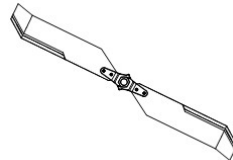


### **3.6.4 Painting**

Painting of blades is optional but must be carried out by suitable qualified tradesman under the supervision of a qualified mechanic or Licensed Aircraft Maintenance Engineer. A high quality 2 pack epoxy is appropriate. Enamel or lacquer type paints are not approved. Static and dynamic rebalancing of the blades IAW Bell 206 Component Repair and Overhaul Manual will be required after painting.

Do not paint the nickel abrasion strip or the exposed portion of urethane adhesive.

Do not use harsh abrasives, paint stripper or chemical solvents for paint removal or cleanup. Clean blades thoroughly with soap and water. Remove grease and oil residue with denatured alcohol soaked rag. Observe precautions listed under Routine Maintenance.



## 4.0 TROUBLE SHOOTING

### 4.1.1 Balancing Difficulty

The AMT-206-1 blades are checked for balance and weight at the factory before being released to service.

No weight is either added or removed from the blades. The weight and balance data is supplied with the blades to assist the installer to correctly balance the blades in accordance with the aircraft manufacturer's requirements.

Weight and balance data is recorded on the A.M.T. Helicopters Pty Ltd production records for each blade manufactured and are kept on file.

If difficulty is experienced in achieving static balance you should contact the factory on +61 7 5495 8000 quoting Part Numbers, Serial Numbers and weight data as recorded on data plate.

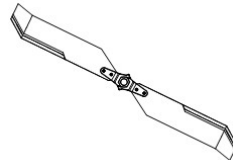
**Note:**

The blade identification plate includes blade part number, blade serial number, weight of blade ex-factory and APMA information required under CASR Part 21, Subpart Q. The data plate should exist affixed at location Blade Station 6.

### 4.1.2 In Flight Vibrations

In flight vibrations are very dangerous and destructive. They are normally caused by one or more of six conditions:

1. Out of balance
2. Icing
3. Worn out Spherical Bearings
4. Loose Spherical Bearings (Spherical Bearing moves from side to side)
5. Loose pitch horn ring
6. Other mechanical problem in tail rotor drive system



## 5.0 SHIPPING RETURN TO FACTORY

### 5.1 REQUIRED PAPER WORK

The AMT-206-1 tail rotor blades must be accompanied by properly filled out and signed off factory supplied Blade Log CTRB-F19 (History Card).

### 5.2 SUGGESTED PACKAGING

The blades should be preferably shipped in the original packing box. Where this is not practical or possible the packaging should address the following requirements:

1. Do not over pack the proposed shipping box.
2. The box should have sufficient packing to prevent movement of the blades.
3. The box should not be bulging after packing.
4. Protect the blades by placing cardboard packing between blades.
5. Protect the trailing edge of each blade by folding cardboard around each trailing edge.
6. Allow sufficient room for the insertion of the Blade Log CTRB-F19 (History Card).
7. Mark the box **FRAGILE** in conspicuous places
8. Clearly address to:

**A.M.T. Helicopters Pty. Ltd.**  
Unit 5/19 Lear Jet Drive  
Caboolture  
Queensland, 4510  
Australia

### 5.3 For questions or service contact:

Telephone: +61 7 5495 8000  
Fax: +61 7 5495 8008  
Email: [info@airwork.com.au](mailto:info@airwork.com.au)  
Web: [www.airwork.com.au](http://www.airwork.com.au)  
Factory Address:  
A.M.T. Helicopters Pty. Ltd.  
Unit 5/19 Lear Jet Drive  
Caboolture 4510  
Queensland  
Australia